

The ACTIVA is a series of photoelectric devices which serve as active infrared barriers. Each device is composed of a transmitter and a receiver units. The ACTIVA barrier is available in seven models which differ among themselves by the number of beams/height:

- ACTIVA-2 (2 beams, height: 52 cm),
- ACTIVA-3 (3 beams, height: 78 cm),
- ACTIVA-4 (4 beams, height: 105 cm),
- ACTIVA-5 (5 beams, height: 130 cm),
- ACTIVA-6 (6 beams, height: 158 cm),
- ACTIVA-7 (7 beams, height: 184 cm),
- ACTIVA-8 (8 beams, height: 210 cm).

This manual applies to the ACTIVA barriers with firmware version 2.00 (or later).

1. Features

- Coding of infrared beams, which prevents swapping of the transmitters (light entering the receiver from another infrared source will be interpreted as beam interruption).
- Beams sensitivity adjustment.
- Option to automatically bypass the beams after preset number of interruptions.
- Option to permanently disable the beams.
- Selectable number of beams whose interruption will trigger an alarm.
- Memory of bypasses.
- Signal strength adjustment (barrier range).
- Programming capability by using the ACTIVA program.
- Tamper switch for detection of an attempt to open the cover or tear the device off the wall.
- Esthetic and durable covers made of aluminum and polyamide.
- Designed to prevent water ingress and allow easy drainage.

2. Description of electronics boards

Electronics boards of the ACTIVA barriers have a modular structure. Depending on the model of the device, they differ by the number of interconnected basic components. Presented below is a description of simplified views of the transmitter and receiver electronics boards.

2.1 Transmitter

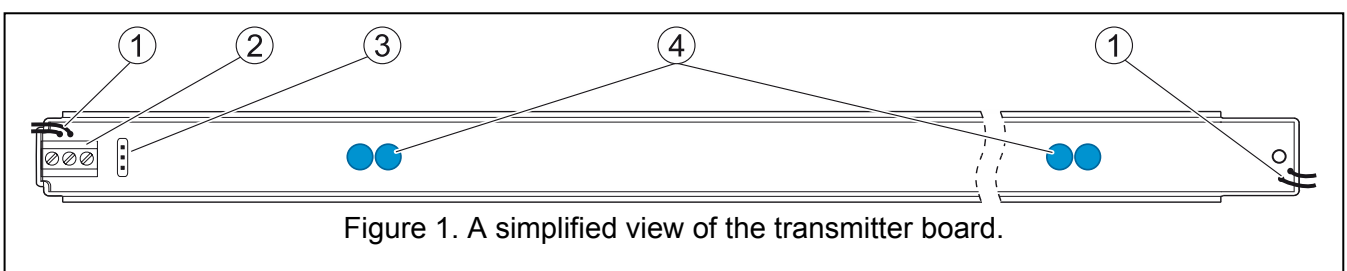
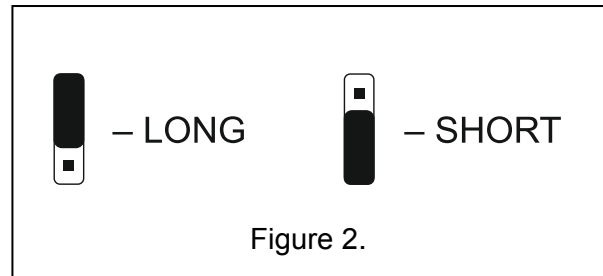

Figure 1. A simplified view of the transmitter board.

Explanations for Figure 1:

- ① tamper switch leads;

- ② terminals:
- 1 - power supply input,
 - 2 - common ground,
 - 3 - synchronization terminal – it must be connected to the counterpart terminal of the receiver,
- ③ pins for setting the beam strength. Depending on the distance between the transmitter and the receiver, set the suitable strength of infrared beams by placing a jumper across the pins on the transmitter electronics board (see: Figure 2): Short – up to 10 meters , Long – up to 20 meters.
- ④ infrared light emitting LEDs.



2.2 Receiver

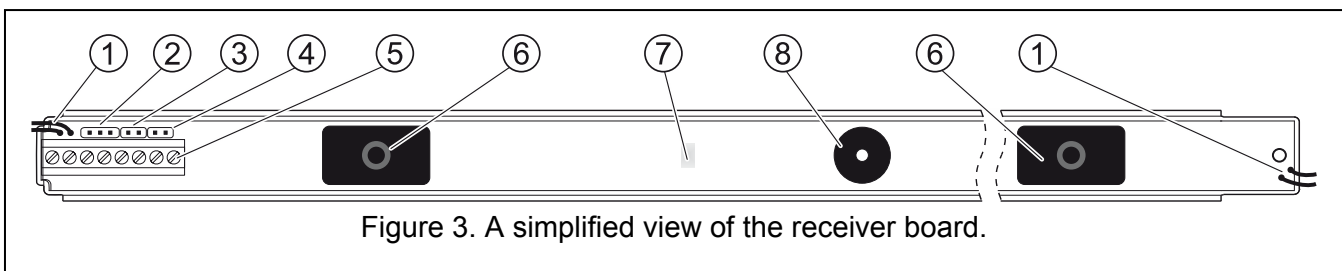

Explanations for figure 3:

- ① tamper switch leads;
 - ② RS-232 port socket – for connecting the barrier to the computer;
 - ③ SAP pins for synchronizing transmitter and receiver;
- Note:** Synchronization can be carried out for 30 minutes after power is turned on. After this time, re-synchronization can be only done after power is turned off and turned on again.
- ④ LED pins. Setting the jumper will activate signaling of the beam interruption by means of the LED (irrespective of the LED input status).
 - ⑤ terminals:
 - 1 - power supply input,
 - 2 - common ground,
 - 3 - synchronization terminal – it must be connected to the counterpart terminal of the transmitter,
 - 4-5 - tamper switch,
 - 6-7 - relay (NC),
 - 8 - the input enables the LED to be remotely switched ON/OFF, if the jumper is removed from the LED pins. With the LED input (terminal 8) shorted to ground, the LED will signal beam interruptions. Besides, each change of this input status will reset the beam interruptions memory. For control of this input, it is possible to use the control panel OC type output, programmed e.g. as SERVICE MODE STATUS or MONO SWITCH.
 - ⑥ infrared receivers;
 - ⑦ LED indicating the device status (covered with epoxy resin). Used when synchronizing the transmitter and receiver, and for indicating the beam interruptions;
 - ⑧ buzzer for communicating beam interruptions (for the first 30 minutes after power-up of the device). One short beep corresponds to interruption of each beam. For example:

a simultaneous interruption of 3 beams will generate a sequence of 3 short beeps; 4 beams – 4 beeps, etc.

3. Installation

Note: Bear in mind during installation that the barrier should not be directly exposed to water (e.g. rain, sprinklers).

Be particularly careful during installation so as to prevent direct sunlight from entering into the receiver (see Figure 4), since this may interfere with the device operation and cause triggering of false alarms.

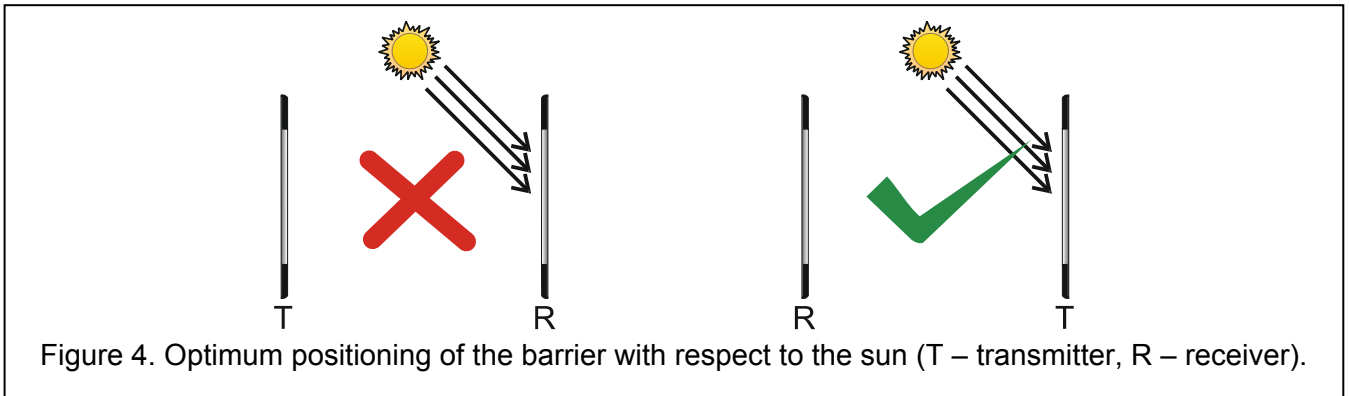

The barriers can be mounted with their power supply leads facing either up or down. However the mounting position in which the cables of transmitter and receiver are oppositely directed (i.e. the cables of transmitter are upward-directed, and those of receiver downward-directed, or conversely – see Figure 5) is not allowed.

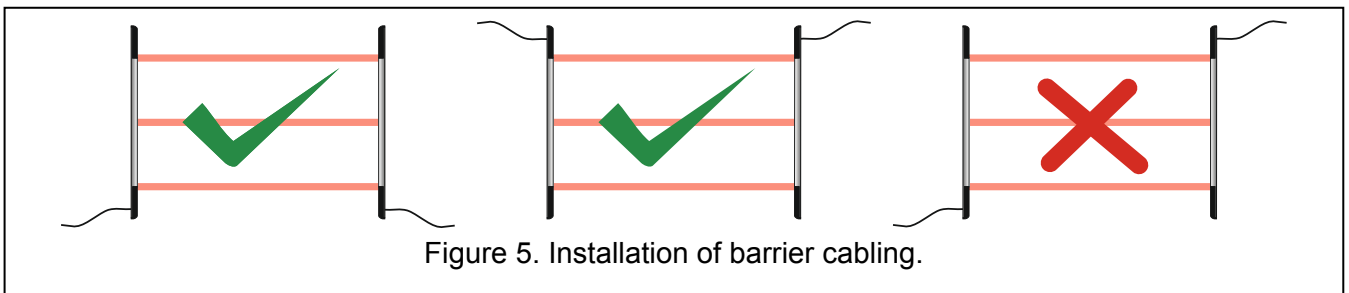

Whenever it is necessary to connect several barriers together (either in parallel or in series), it should be borne in mind that transmitters and receivers must be suitably positioned (see Figure 6).

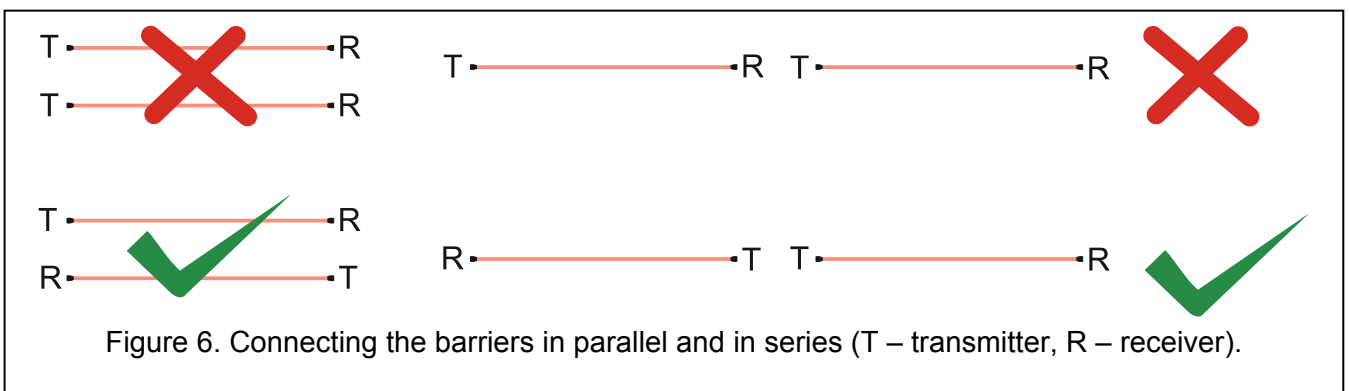

3.1 Mounting perpendicular to the wall plane

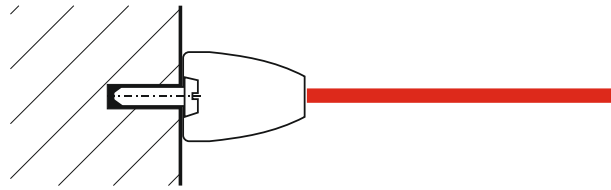

Figure 7. Pictorial top view of the barrier panel mounted directly to the wall.

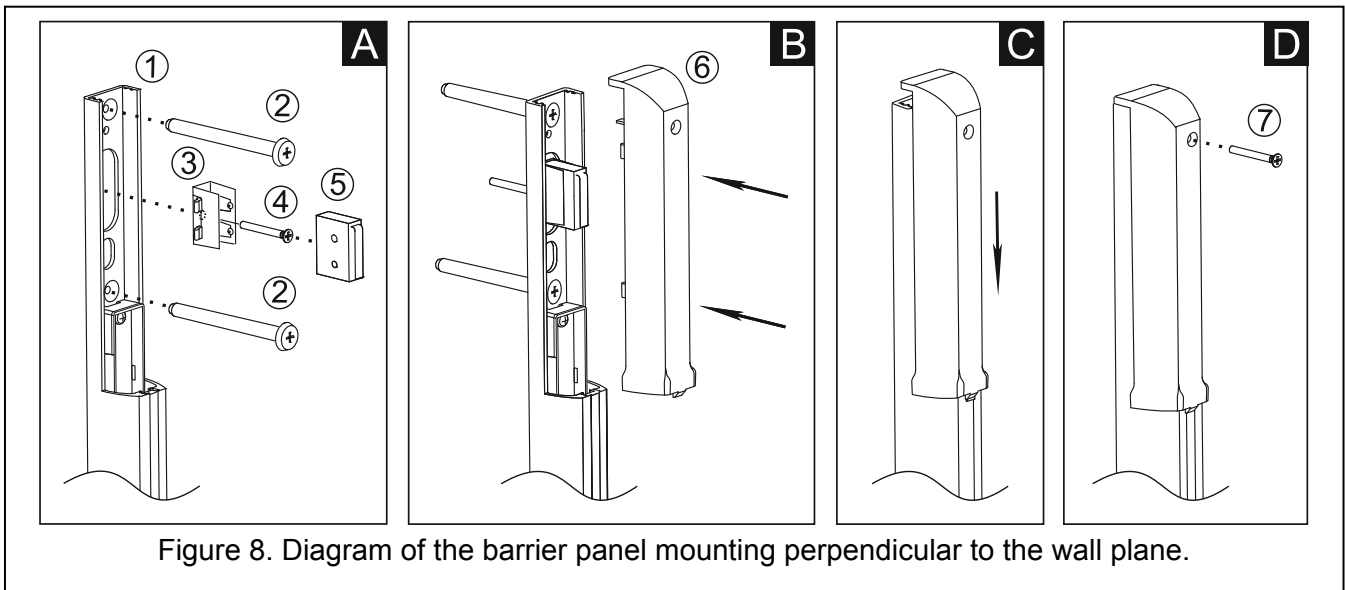

Figure 8. Diagram of the barrier panel mounting perpendicular to the wall plane.

- A** Attach the rear panel of the barrier housing (1) to the wall, using the screws (2). Insert the tamper switch holder (3) into the mounting plate guides and secure it to the wall with the screw (4). Insert the tamper switch (5) into the secured holder.
- B** Connect the power supply cables the and synchronizing cable. Place the housing cover (6).
- C** Push the cover in position.
- D** Secure the cover, using the screw (7).

3.2 Mounting parallel to the wall plane

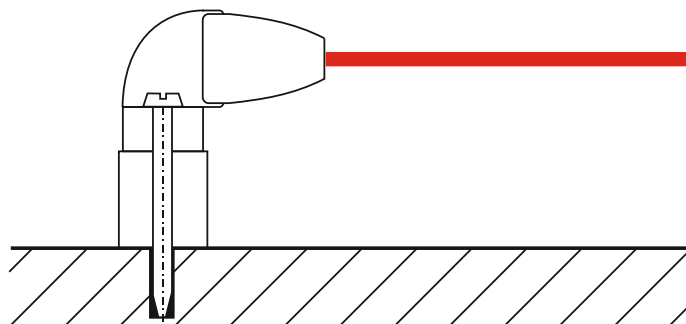

Figure 9. Pictorial top view of the barrier panel mounted on a holder.

- A** Insert the rear panel of the barrier housing (2) into the angular holder (1). Screw the two components together with screws (3). Insert the tamper switch holder (4) into the mounting plate guide (2) and tighten it with the screw (5). Insert the tamper switch (6) into the secured holder.

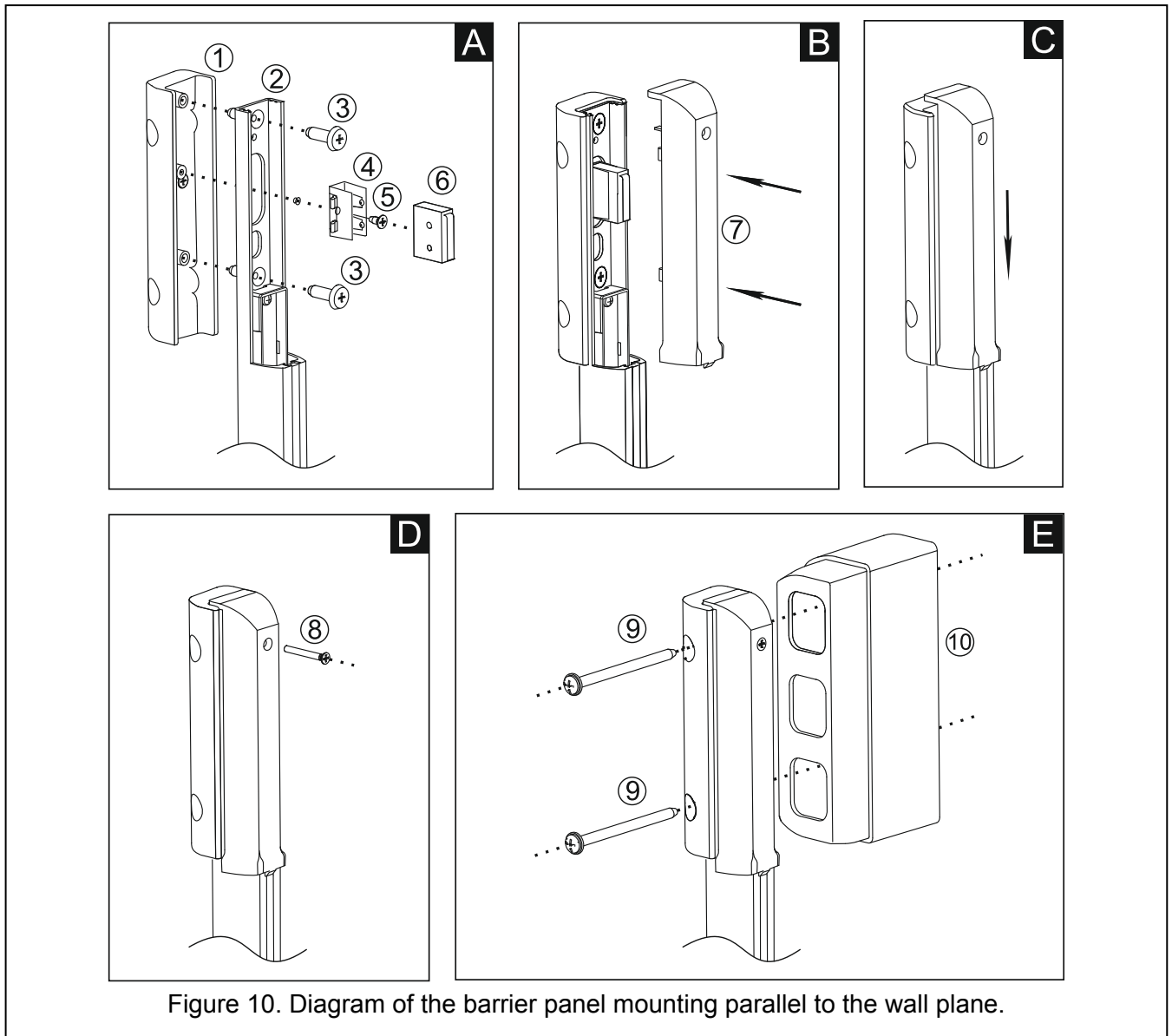

Figure 10. Diagram of the barrier panel mounting parallel to the wall plane.

- B** Connect the power supply cables and the synchronizing cable. Connect both tamper switches in series (to do so, cut the longer cable of the mounting plate tamper switch and solder its ends, as required, to the cables of angular holder tamper switch). Place the plastic cover of the housing (7).
- C** Push the cover in position.
- D** Secure the cover, using the screw (8).
- E** Using the screws (9), attach the holder to the wall. If the installation requires that the barrier be positioned at a distance from the wall (in case when the beam path is obstructed by elements protruding from the wall, e.g. parapet, drain pipes, etc.), use the spacers (10) – as they can be connected together, the distance between the barrier and the wall is adjustable. A single spacer makes it possible to move the barrier panel away from the wall by 6 cm, and each next – by additional 4 cm. The spacers are not provided with tamper switch.

4. Configuration

Start-up and basic configuration of the ACTIVA barriers can be done manually by placing jumpers over pins directly on the device electronics board. Full configuration and diagnostics of the devices is only possible from a computer with the ACTIVA program installed.

4.1 Manual configuration

1. Connect the power supply cables and sync cable to the device.
2. Position the transmitter and the receiver opposite each other so that nothing can block the path of their IR beams.
3. Remove the jumper from the SAP pins (see description of pins designated ③ in Fig. 3).
4. Power up the transmitter and receiver. The indicator LED will start blinking rapidly.
5. Wait until the LED blinking goes slower and then place a jumper over the SAP pins – this will complete the synchronization process **and restore the factory default settings of the barrier** (**Beam sensitivity** is set at 120 ms, alarm is triggered by interruption of two beams, **Autobypass** of the beams is disabled, **Maximum time of all beams interruption** is set at 0).
6. If the LED is to signal interruption of the beams (irrespective of the LED input status – terminal 8), place a jumper over the LED pins.

4.2 Configuration by using computer

The barrier delivery set includes the ACTIVA configuration/diagnostics program intended for IBM PC/AT compatible computers. It operates on any hardware configuration in the **WINDOWS** environment. The program should be installed on the computer hard disk (by launching the **Activa.exe** program).

The ACTIVA barriers communicated with the computer through the RS-232 interface. To connect the barrier to the computer, use the USB-RS converter for programming SATEL devices.

In order to configure the barrier by using computer, follow the procedure below:

1. Connect the power supply cables and the sync cable to the device.
2. Connect the barrier to the computer.
3. Make sure that the beam path is not obstructed by any obstacles.
4. Power up the transmitter and receiver.
5. Start the ACTIVA program and select the port through which communication will be effected (**Configuration →RS-232**). If connection with the barrier is established, the color of the program status bar will change to green (gray color means no connection).
6. Carry out synchronization of the transmitter and the receiver. For this purpose, enter in the program the factory assigned **Receiver serial number** (the serial number sticker is placed on the transmitter) and save the data to the barrier memory.
7. Program the device as required and save the data to the barrier memory.

Explanations for Figure 11:

- 1 - **Transmitter serial number** – a unique identification code of the device (5-digit number from 0–65535 range).
- 2 - **Beams parameters:**
 - Sensitivity** – the amount of time (counted in milliseconds, within the 40–1000 range) a beam must be interrupted to barrier detect the interruption (entering 0 will permanently disable the beam).
 - Autobypass** – number of interruptions of a given beam (within the 0–255 range) after which it will be automatically bypassed (0 – no bypassing).
 - Autobypass counting time** – the amount of time (counted in seconds, within the 0–255 range) during which consecutive beam interruptions are counted until the beam is automatically bypassed (0 – no counting).
 - Maximum time of all beams interruption** – the amount of time (counted in minutes, within the 0–255 range) after expiry of which all beams interruption will be interpreted as device tamper (0 – no response).

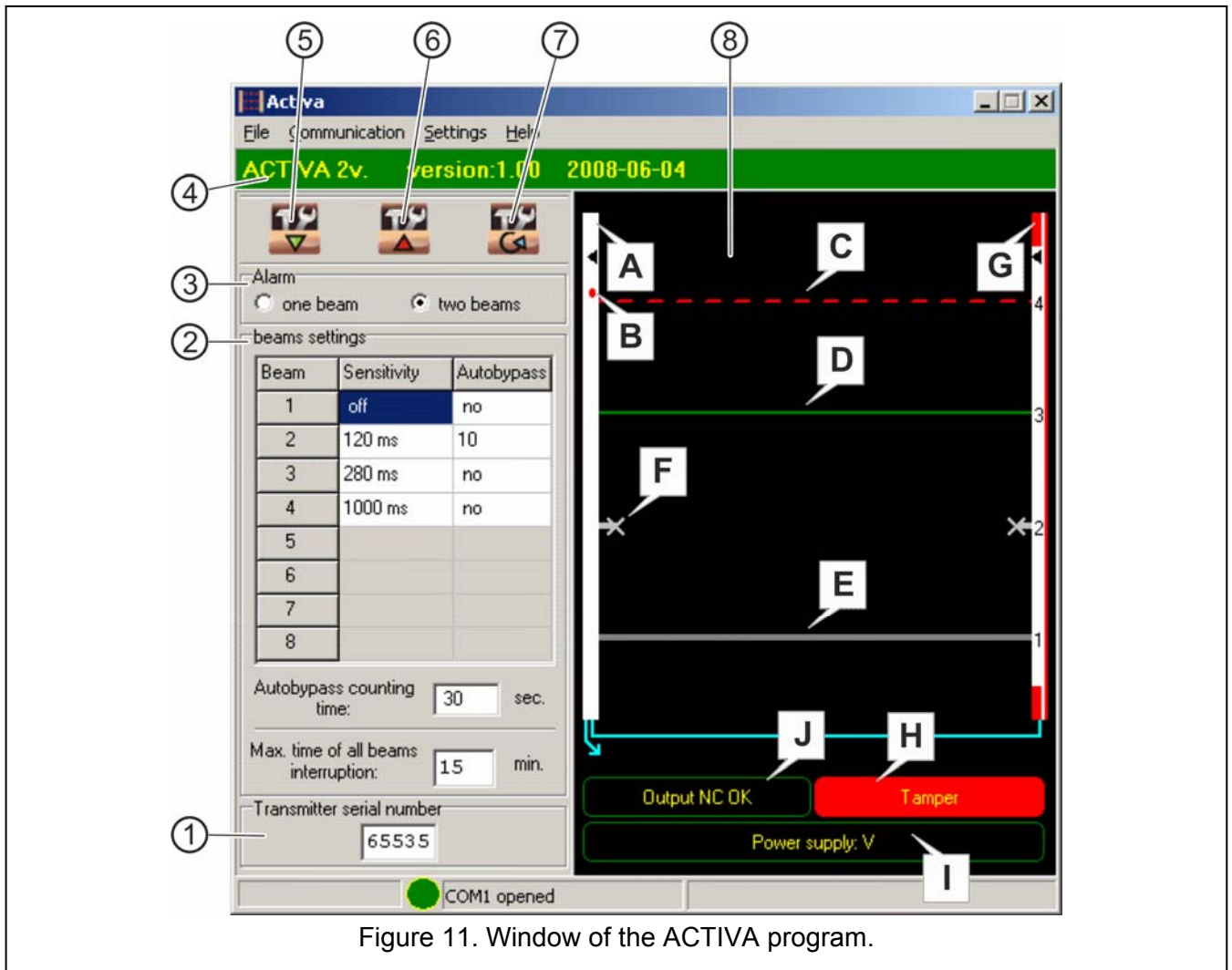

Figure 11. Window of the ACTIVA program.

- 3 - **Alarm** – parameter which specifies whether an alarm will be already triggered after interruption of one, or at least two beams.
 - 4 - **Communication status bar** – the following information is displayed on the bar:
 - model of the connected device (ACTIVA-4),
 - firmware version and build date of the connected barrier.
 - 5 - Button for reading data from barrier memory.
 - 6 - Button for writing data to barrier memory.
 - 7 - Button for erasing the memory of bypasses.
 - 8 - Diagnostic window. The window displays the following information:
 - A** Receiver. In the ACTIVA program, its color can be as follows:
 - white – normal running mode of the device,
 - red – tamper of the receiver,
 - blue – synchronization of the transmitter and the receiver.
 - B** LED – indicates interruption of the beams (if jumper is placed over the LED pins on the receiver electronics board),
 - C** Beam is interrupted (broken line, red color). Interruption of the beam path lasted longer than the time programmed with the **Beam sensitivity** parameter.
- Note:** If the beam is interrupted for a shorter time than the programmed sensitivity, the program will indicate this by changing the color of the given beam to:
- light green – the beam was interrupted for a shorter time than half the value defined for sensitivity,

- *yellow – the beam was interrupted for a longer time than half the value defined for sensitivity.*
- D** Beam is not interrupted (continuous line, green color),
- E** Beam is disabled (continuous line, gray color),
- F** Beam is bypassed (if the number of interruptions specified in the **Autobypass** parameter is reached during the **Counting time**). The beam will be unbypassed when:
 - the LED input status is changed,
 - the bypass memory is reset.
- G** Transmitter. Red color (as in Figure 11) means that the transmitter tamper input has been violated,
- H** Tamper switch indicator. It can indicate two states:
 - Output TMP OK,
 - Tamper (as in Figure 11).
- I** Power supply indicator – it shows the current voltage level across the barrier terminals,
- J** Alarm output indicator. It can indicate two states:
 - Output NC OK (as in Figure 11),
 - Alarm.

5. Specifications

	ACTIVA-2	ACTIVA-3	ACTIVA-4	ACTIVA-5	ACTIVA-6	ACTIVA-7	ACTIVA-8
Nominal power supply voltage $\pm 15\%$	12 V DC						
Current consumption, standby	40 mA	40 mA	40 mA	40 mA	40 mA	45 mA	45 mA
Current consumption, maximum	45 mA	45 mA	45 mA	50 mA	50 mA	50 mA	50 mA
Operating temperature range	-25...+55 °C						
Range (adjustable)	10/20 m						
Emitted wavelength	950 nm						
Hight	52 cm	78 cm	105 cm	130 cm	158 cm	184 cm	210 cm
Panel depth	26 mm						
Panel width	25 mm						
Distance between first beam and laminate edge with terminal block - barrier lower part	148 mm						
Distance between the first and the second beam	245 mm						
Distance between the other beams	265 mm						
Distance between last beam and laminate end – barrier upper part	125 mm						
Weight	500 g	750 g	1050 g	1250 g	1450 g	1750 g	2000 g